

**WPNP-400NI-PIDS-D
Non-Porous Web Printer**

U.S. PATENT NO. 5,109,769 E.P. PATENT NO. 0508971

The WPNP-400NI is now available in a PIDS model. With a print width capacity of 4" (100 mm) and a print drum circumference of 19.68" (500 mm) this system is ideal for printing large text messages and logos on continuous web materials. These non-indexing, top mount printers have a rugged, dual frame, anodized aluminum construction with stainless steel shafts and axles and a modular inking system which can be removed from the printer in a matter of seconds without the use of tools.

The PIDS Systems enable the use of bulk ink reservoirs and a wide variety of fast drying dye and pigmented inks can be used in the system including Universal #100, Type D and Type M for marking on plastic films, metal rubber and glass materials.

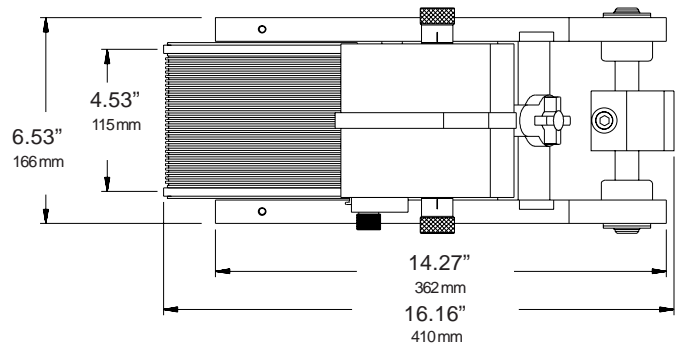
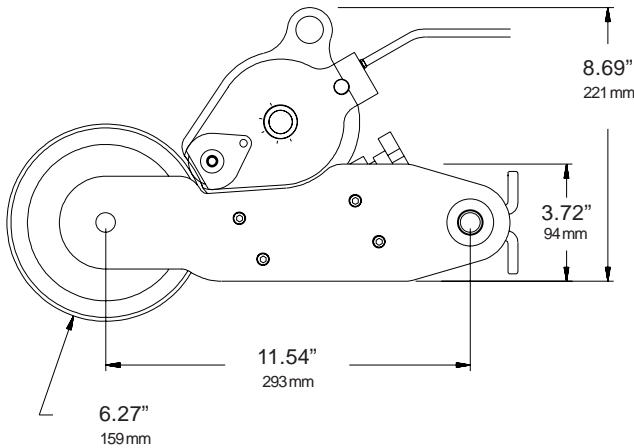

PIDS-200 Programmable Ink Delivery System

The PIDS System is an advanced method of supplying ink "on-demand" to contact roll coding equipment. This system combines the simplicity of electronic programming and the accuracy of peristaltic metering pumps to automatically deliver precise amounts of a variety of fast drying dye and pigmented inks to the coders at prescribed intervals. Ink is transferred to the pre-inked XF Neoprene Ink Roll through a special wiper adapter. The wipers transform the ink into a very thin film which is then evenly spread across the entire face of the roll.

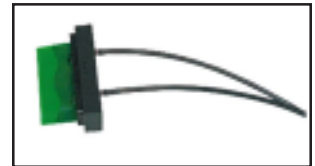

Wiper Adapter



Model Shown: PIDS-200

The PIDS systems uses positive displacement peristaltic pump heads to move ink through progressive waves of contraction and relaxation of a resilient pump tube. The ink never touches any of the pumps component parts so maintenance is limited to replacing the pump tube after approximately 1,000 hours of operation. Universal's quick disconnect replacement pump tube assembly, facilitates pump tube changes in less than 10 seconds. This design provides instantaneous coder response, ensures uniform print density over the full print width of the coder at an affordable cost!

Manufactured By

Universal Stenciling & Marking Systems, Inc.

P.O. Box 871 • St. Petersburg, FL 33731 • U.S.A.

Ph: (727) 894-3027 • E-Mail: sales@universal-marking.com • Website: www.universal-marking.com